

Squash

History

“Variations of squash originated in England in the early 1800s; use of a softer ball—one that could be “squashed” by a player’s hand—gave rise to the game’s name. Squash was introduced in America in the mid-1800s. While there are hard ball and soft ball versions of the game, the soft ball version is much more popular and is played internationally.

As with many racquet games, squash may be played by two or four players. Players hit a small rubber ball against the front wall, above the tin and within the outside-of-court lines, attempting to score points by hitting the ball in such a way that the opponents cannot return it before it bounces twice.

Procedures

A singles game is played to 11 points; a match is the best of three or best of five games. Players take a 90-second break between games. If the score reaches 10-10, the receiver may choose to “set” to two points, which means the first player to win by two points wins the game. Before play begins, players may warm up the ball on the court for five minutes. A spin of the racquet determines which side gets first serve.

When a good serve is delivered, the opposing side attempts to return the serve. Hits continue to alternate from side to side until the rally is over. Point-A-Rally (PAR) scoring is used, so either team can score a point when serving or receiving. In doubles, games go to 15 points, with a point per rally and are played on a much larger court.

Play is continuous throughout the game except for injury. Players may be coached only during the intervals between games, not while the game is in session.

Serving

At the beginning of a game and when a receiver becomes a server, the server may choose to serve from either service box. Part of one foot must be on the floor in the service box, with no part of the foot touching the service box line when the server strikes the ball. The server drops or throws the ball to begin the serve and must hit it before it bounces on the floor. The served ball may not hit any surface before striking the front wall. It must strike the front wall between the cut line and the out line so that it reaches the floor within the quarter court opposite the server’s box (unless volleyed by the opponent).

A server who drops or throws the ball and then does not attempt to hit it may serve again. A server continues to serve until she loses a stroke. As long as she holds serve, she alternates boxes. If a rally ends in a let (an undecided point), she serves again from the same box. In singles play, when a player loses serve, the serve then passes to the receiver. At the beginning of the second and subsequent games, the winner of the previous game serves first. A server “serves her hand out” (loses her serve) when:

- Her serve first hits a side wall, floor, or ceiling;
- Part of one foot is not on the floor in the server's box, with no part of that foot on the box line, when she strikes the ball; or
- The ball bounces on or outside the short or half-court line of the quarter court opposite the service box.

A serve is also lost when a server

- Attempts and fails to hit a serve,
- Does not strike the ball correctly (e.g., hits the ball more than once or carries the ball with the racquet),
- Serves the ball out
- Serves onto or below the cut line, or
- Is struck by her own serve before the opponent can strike at it.

Rallies

Making a return. A good serve may be returned before the ball strikes the ground or after it bounces once. It must hit the front wall above the board before touching the ground. It may not touch any part of the striker's body or clothing, or any part of the opponent's body, clothing, or racquet.

Hitting an opponent with the ball. If a striker hits an opponent with the ball, the striker wins the stroke if the return would have struck the front wall without first touching any other surface. The exception is if the striker has followed the ball around and turned to strike the ball to the right of her body after it has passed to his left, or vice-versa—that is, after the ball has passed the striker, struck the back wall, and the striker turns to hit the ball to the front wall. This is an example of “turning,” and while the rules do not specifically prohibit turning, it is deemed a dangerous maneuver, because the striker loses sight of her opponent. Players are strongly encouraged to call “let” in this case. If a player does strike a ball while turning and the ball strikes the opponent, it's a let.

If a striker hits an opponent with the ball, and the ball hits another wall before touching the front wall, a let is called.

Making every effort. The outgoing striker must make every effort to allow the incoming striker a clear path to the ball. It is also the incoming striker's responsibility to make every effort to get to the ball.

Interference. To avoid interference, a player must make every effort to provide her opponent with unobstructed, direct access to the ball; a fair view of the ball; and freedom to hit the ball directly to the front wall. If interference is called, the play is a let, or a stroke is awarded to the offended player. A let is not allowed if the player would not have made a good return, if she did not make adequate effort to get to and play the ball, if she created her own interference, or if she clearly accepted the interference and played on.

A let is always allowed if one player refrains from striking the ball due to a reasonable fear of striking her opponent with the ball or with the racquet. This is the case even if no interference occurred.

Lets. In addition to previous mentions of lets, rallies are replayed when

A player is distracted by an occurrence on or off the court,
The receiver is not ready for the serve and doesn't attempt to return serve,
The ball breaks during play, or
Court conditions affect play (e.g; ball from another court enters your court).

Terms

The **board** is the lowest horizontal marking on the front wall, with the tin beneath it stretching the width of the court. The tin is between the board and the floor, running the length of the floor. It makes a distinctive noise when the ball hit it.

The **cut line** is a horizontal line across the front wall, 6 feet above the floor.

“Down” is the expression used when an otherwise good serve strikes the board or tin or fails to reach the front wall. It is also used when the ball strikes a player before it has bounced more than once.

“Game ball” means that the server or receiver needs one point to win the game.

“Match ball” means that the server or receiver needs one point to win the match.

The **half-court line** runs parallel to the side walls, dividing the court into two equal parts, intersecting the short line to form a “T”.

The **short line** is parallel to and 18 feet away from the front wall.

A **hand** refers to the time during which a player has the serve.

A **“handout”** means the serve is changing hands.

The **out line** is a continuous line comprising the front wall line, both side wall lines, and the back wall line. This line marks the top boundaries of the court. If there is no side wall or back wall lines, the boundaries are the tops of the walls. If a ball strikes part of the horizontal top surface of such an unlined wall, it is out, even if it rebounds into the court.

A **rally** is the play that begins with the serve and ends when the ball is no longer in play.

A **service box** is in each quarter court, bounded by the side wall, the short line. Two other lines form a small box within the quarter court.

The **striker** is the player whose turn it is to hit the ball.

A **stroke** is gained by the player who wins a rally. A stroke results in either a point scored for the server or the receiver.”

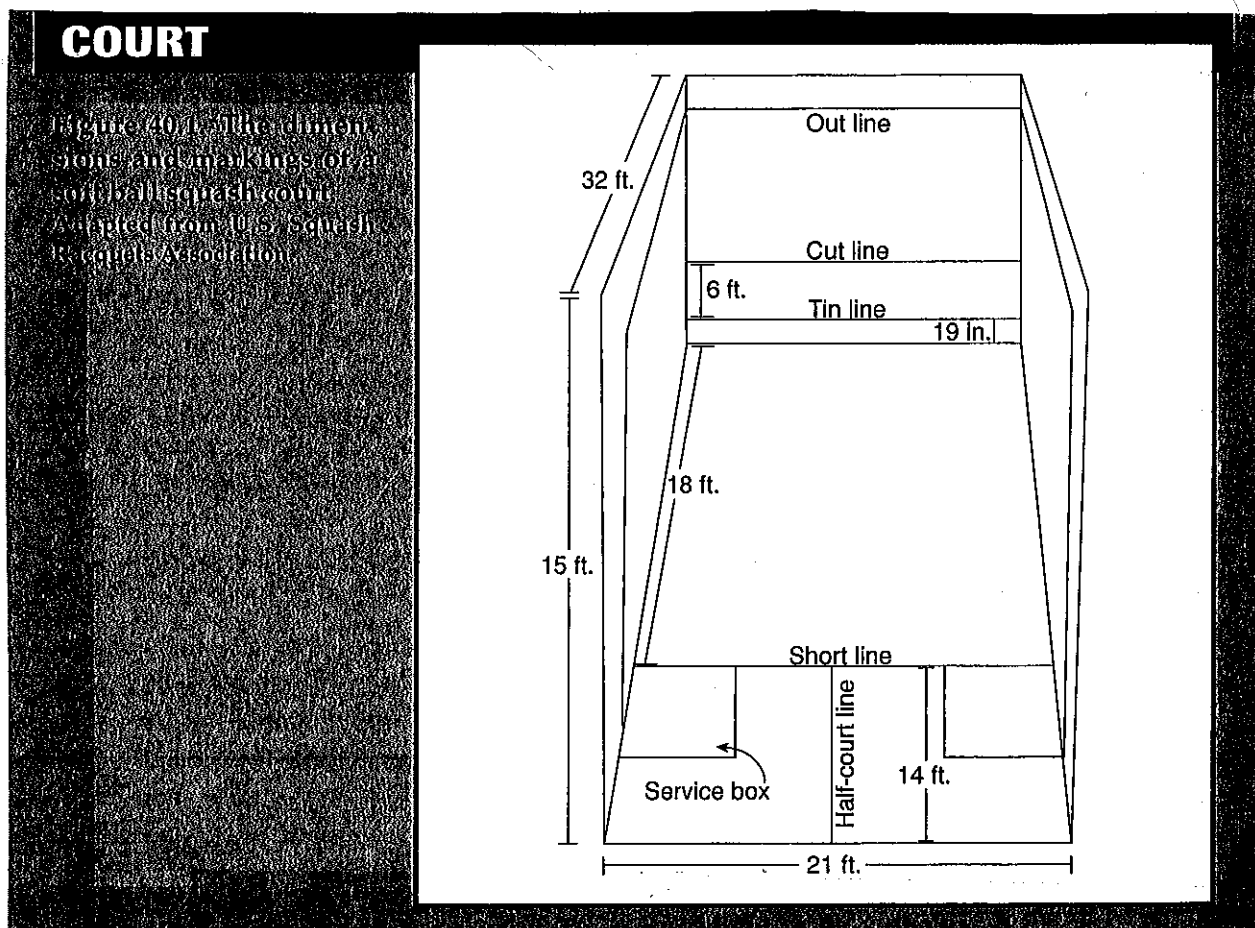

Squash Rubric – Skills

Name _____ Date _____

Composite Score _____

	100-93%	92-85%	84-77%	76-70%	69-60%	59% and below
Serve	Always serves with good form, power and location with no teacher assistance.	Consistently serves with good form, power and location with no teacher assistance.	Somewhat consistent form – has 50-60% success rate; some teacher reminders.	Somewhat erratic form – has 30-50% success rate	Erratic form – 0-20% success rate with adaptations for distance from the front wall	Seldom serves the ball in even with adaptations.
Forehand	Always demonstrates good stroke mechanics. Shots have power and good location.	Consistently demonstrates good stroke mechanics. Shots have moderate power and consistent location.	Form is somewhat consistent, and can sustain a short rally. Shot lacks power.	Form is somewhat inconsistent and has difficulty in sustaining a short rally. Shot lacks power and location.	Inconsistent stroke mechanics. Has difficulty hitting the ball to the front wall. Unable to sustain a rally. Shot has no power.	Form is very poor and erratic. Has difficulty making contact with the ball.
Backhand	Always demonstrates good stroke mechanics. Shots have power and good location.	Consistently demonstrates good stroke mechanics. Shots have moderate power and consistent location.	Form is somewhat consistent, and can sustain a short rally. Shot lacks power.	Form is somewhat inconsistent and has difficulty in sustaining a short rally. Shot lacks power and location.	Inconsistent stroke mechanics. Has difficulty hitting the ball to the front wall. Unable to sustain a rally. Shot has no power.	Form is very poor and erratic. Has difficulty making contact with the ball.
Reaction, Movement, Positioning	Proper grip, good footwork, balance, anticipation, always returns to the “T”.	Proper grip, good balance, footwork, & form, consistently returns to the “T”.	Somewhat inconsistent grip acceptable balance & footwork, somewhat inconsistently (50-60%) returns to the “T”.	Inconsistent grip, uncertain balance & footwork, incorrect form, inconsistently (30-50%) returns to the “T”.	Improper grip, off-balance, with poor footwork, occasionally returns to the “T”.	Improper grip, off-balance, with poor footwork, never returns to the “T”.